

Alternating Relay

Alternating Control Model #ALTDIN21

The **Model ALTDIN21** alternating relay is designed for alternating controls to increase life of loads by sharing run times. It comes in the popular DIN rail mount case. Two models meet wide power supply requirements. External cross wiring allows lead-lag controls. An open on the control input allows the internal relay to switch between two loads as displayed by the LED's. Applications include waste water and HVAC controls for duplex alternating pumps, compressors, blowers, solenoids, etc.

Features

- Wide power supply input
- DIN mount base
- Alternate 2 loads (duplex)
- 10A, 250Vac rated output

Benefits

- AC model has 90-260Vac input
- Industry standard
- Covers all applications
- Industrial rated output relay

Technical Data:

Input (Model HV).....	90 to 260Vac
Input (Model LV).....	12 to 35 Vac/Vdc
Frequency.....	50 to 60Hz
Max. Power Consumption.....	2VA
Output.....	10A resistive 250Vac/30Vdc
Isolation.....	≥1500 V RMS
Temp. Rating.....	-10°C to 60°C 14°F to 140°F
Mounting.....	DIN rail
Approvals.....	Pending



Ordering Information

Model #	#Loads	Input	Rev 2/10 List Price (US\$)
ALTDIN21-HV.....	2	90-260 Vac.....	\$64.00
ALTDIN21-LV	2	12-35 Vac/Vdc.....	\$64.00

FAX Orders: (888) 393-8529
PHONE Orders: (802) 295-1400
EMAIL Orders: sales@ntcontrols.com

NT Controls, Inc.
PO Box 4150
White River Junction, VT 05001

Alternating Relay Model #ALTDIN21

Dimensions: Inches (millimeters)

Model	H	W	D
ALTDIN21	2.76 (70.1)	2.57 (65.3)	4.42 (112.3)

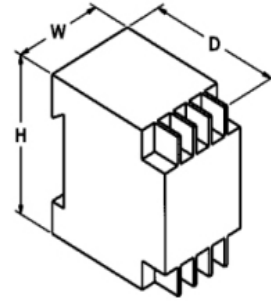

Applications:

Alternating Example (Model ALTDIN21):

Power should be applied to pins 1 and 2 at all times. In the off state, the control switch is open (pin 3) and the alternating relay is energized in the OUT1 position. When the control switch closes (pin 3 to pin 1), the OUT1 load is energized. When the control switch opens, the alternating relay is energized in the OUT2 position and the OUT2 load is energized. And the process repeats itself between OUT1 and OUT2.

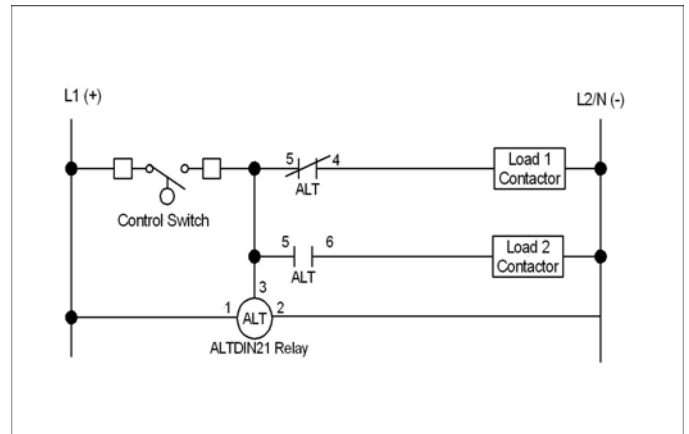

Duplex (Lead/Lag) and Alternating Example (Model ALTDIN21):

Power should be applied to pins 1 and 2 at all times. In the off state, the low float switch is open (pin 3) and the alternating relay is energized in the OUT1 position. When the low float switch closes (pin 3 to pin 1), the OUT1 load is energized. When the low float switch opens, the alternating relay is energized in the OUT2 position and the OUT2 load is energized. And the process repeats itself between OUT1 and OUT2. If at any time the High float switch closes it energizes the other unused load creating duplex or lead lag controls.

