

# Alternating Relay

## Duplex Control Model #ARP81

The **Model ARP81** alternating relay is designed for alternating duplex controls to increase life of loads by sharing run times. It comes in the popular 8 pin plug in type relay case. Two models meet wide power supply requirements. External cross wiring allows duplex lead-lag controls. An open on the control input allows the internal relay to switch between two loads as displayed by the two LED's. Applications waste water and HVAC controls for duplex and/or alternating pumps, compressors, blowers, solenoids, etc.

### Features

- Wide power supply input
- Octal type relay base
- Duplex and/or Alternating
- 10A, 250Vac rated output

### Benefits

- AC model has 90-260Vac input
- Industry standard
- Covers all applications
- Industrial rated output relay

### Technical Data:

Input (Model HV).....	90 to 260Vac
Input (Model LV).....	12 to 35 Vac/Vdc
Frequency.....	50 to 60Hz
Max. Power Consumption.....	2VA
Output.....	10A resistive 250Vac/30Vdc
Isolation.....	≥1500 V RMS
Temp. Rating.....	-10°C to 60°C 14°F to 140°F
Mounting.....	Octal plug
Approvals.....	Pending



### Ordering Information

Rev 2/10

Model #	Input	List Price (US\$)
ARP81-HV.....	90-260 Vac.....	\$44.00
ARP81-LV.....	12-35 Vac/Vdc.....	\$44.00
BASE8DIN.....	Socket, DIN mount.....	\$6.00

FAX Orders: (888) 393-8529  
PHONE Orders: (802) 295-1400  
EMAIL Orders: [sales@ntcontrols.com](mailto:sales@ntcontrols.com)

NT Controls, Inc.  
PO Box 4150  
White River Junction, VT 05001

## Alternating Relay Model #ARP81

### Dimensions:

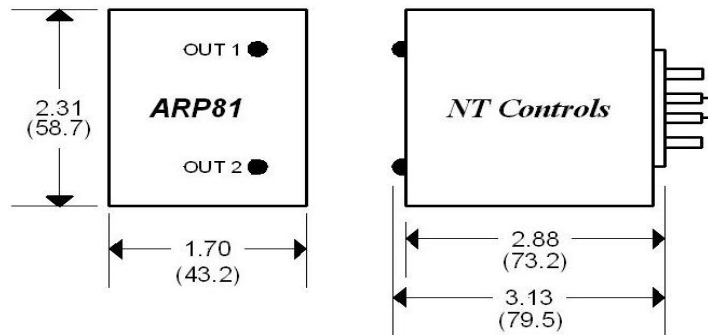

Inches (millimeters)

### Applications:

#### **Alternating Example:**

Power should be applied to pins 4 and 3 at all times. In the off state, the control switch is open (pin 5) and the alternating relay is de-energized in the OUT1 position. When the control switch closes (pin 5 to pin 4), the OUT1 load is energized. Alternating relay is de-energized in the OUT1 position.

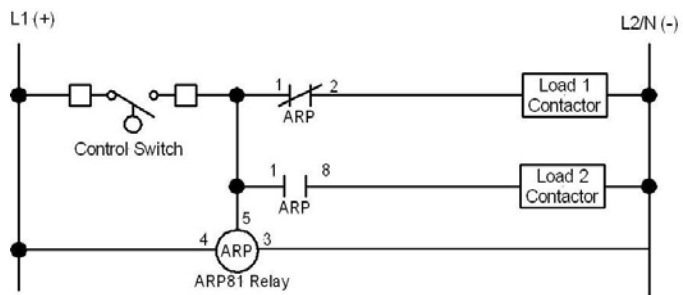

When the control switch opens, the alternating relay is energized in the OUT2 position and the OUT2 load is energized. And the process repeats itself between OUT1 and OUT2.

#### **Duplex (Lead/Lag) and Alternating Example:**

Power should be applied to pins 4 and 3 at all times. In the off state, the low float switch is open (pin 5) and the alternating relay is de-energized in the OUT1 position. When the low float switch closes (pin 5 to pin 4), the OUT1 load is energized. Alternating relay is de-energized in the OUT1 position. When the low float switch opens, the alternating relay is energized in the OUT2 position and the OUT2 load is energized. And the process repeats itself between OUT1 and OUT2.

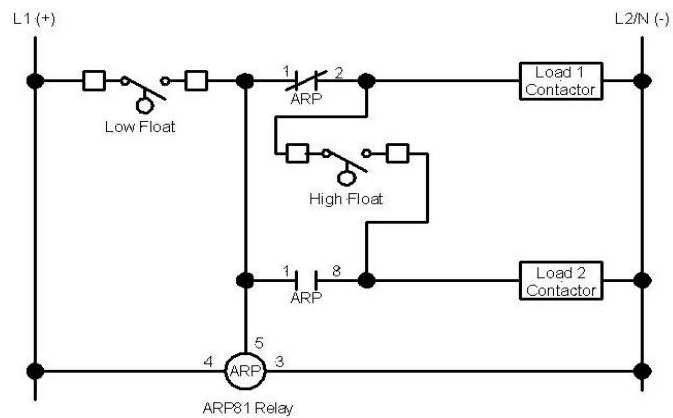

If at any time the High float switch closes it energizes the other unused load creating duplex or lead lag controls.